

QUADRO DE PROTEÇÃO CA (QDCA/92)

QUADRO DE PROTEÇÃO E ISOLAMENTO DA REDE



Dimensões

197X210X95 mm (L X A X P)



Rua São Bernardino nº 12
Pq. Anhanguera - CEP: 05120-050
São Paulo - SP



(11) 3648-7830
contato@phb.com.br

phb[®]
Solar

Composição do quadro de proteção CA.

Modelo	QDCA/92
Tensão de Entrada	127Vca
Dimensões	197X210X95mm (L X A X P)
Grau de proteção	IP65
Dispositivo de proteção contra surto	(2) DPS classe II com IEC 61643-11 I _{max} 45kA. Tensão máxima de operação contínua: 175Vca
Disjuntor	(1) Monopolar Curva C 32A
Bitola do cabo	6mm ²

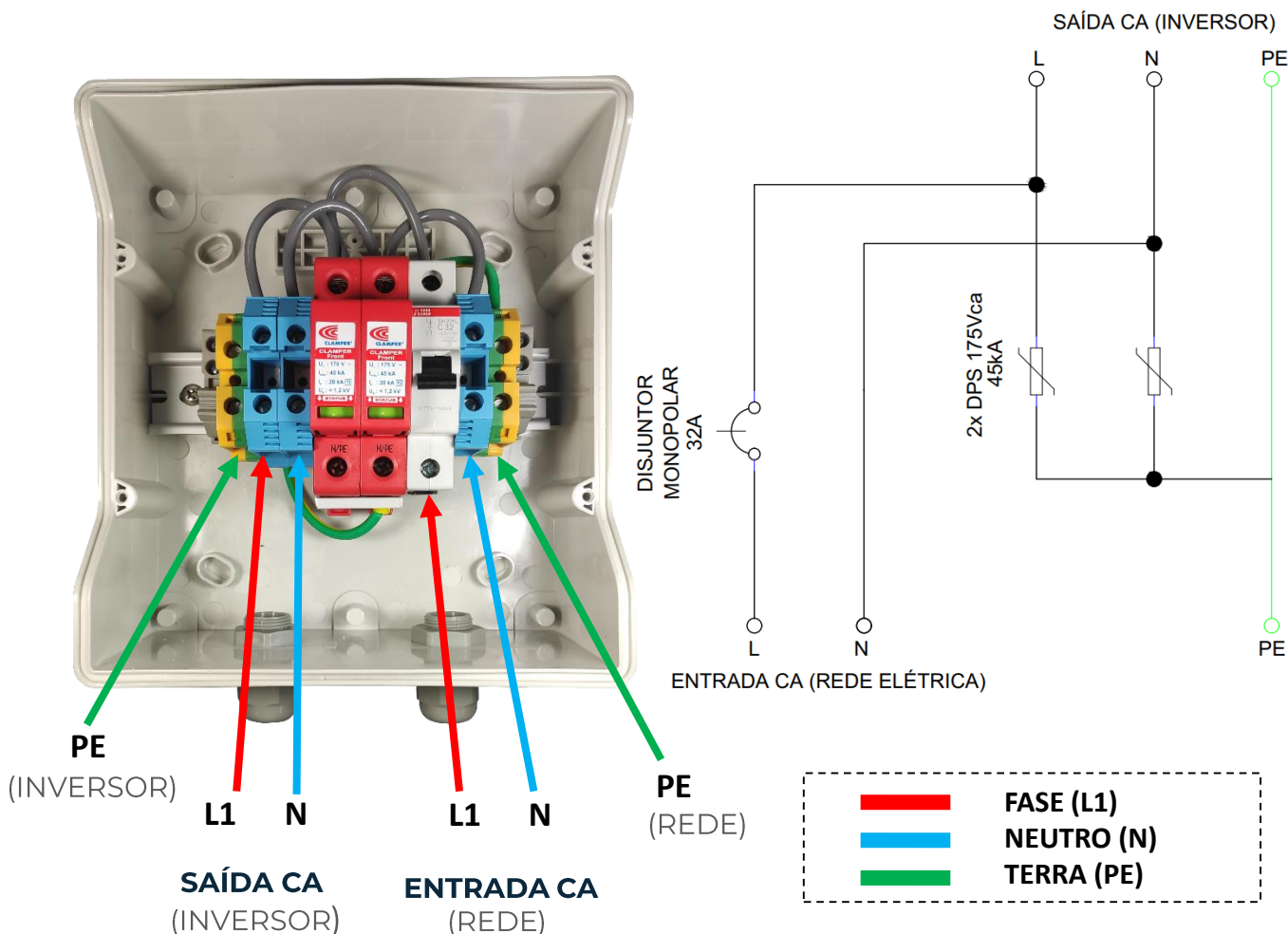

Rua São Bernardino nº 12
Pq. Anhanguera - CEP: 05120-050
São Paulo - SP



(11) 3648-7830
contato@phb.com.br

