

# QUADRO DE PROTEÇÃO CA (QDCA/84)

QUADRO DE PROTEÇÃO E ISOLAMENTO DA REDE



**Dimensões**

197X210X95mm (L X A X P)



Rua São Bernardino nº 12  
Pq. Anhanguera - CEP: 05120-050  
São Paulo - SP



(11) 3648-7830  
contato@phb.com.br



# Composição do quadro de proteção CA.

| Modelo                               | QDCA/84  |
|--------------------------------------|--|
| Tensão de Entrada                    | 220Vca   |
| Dimensões                            | 197X210X95mm (L X A X P)   |
| Grau de proteção                     | IP65   |
| Dispositivo de proteção contra surto | (2) DPS classe II com IEC 61643-11 I <sub>max</sub> 40kA. Tensão máxima de operação contínua: 275Vca |
| Disjuntor                            | (1) Bipolar Curva C 20A  |
| Bitola do cabo                       | 4mm <sup>2</sup>   |

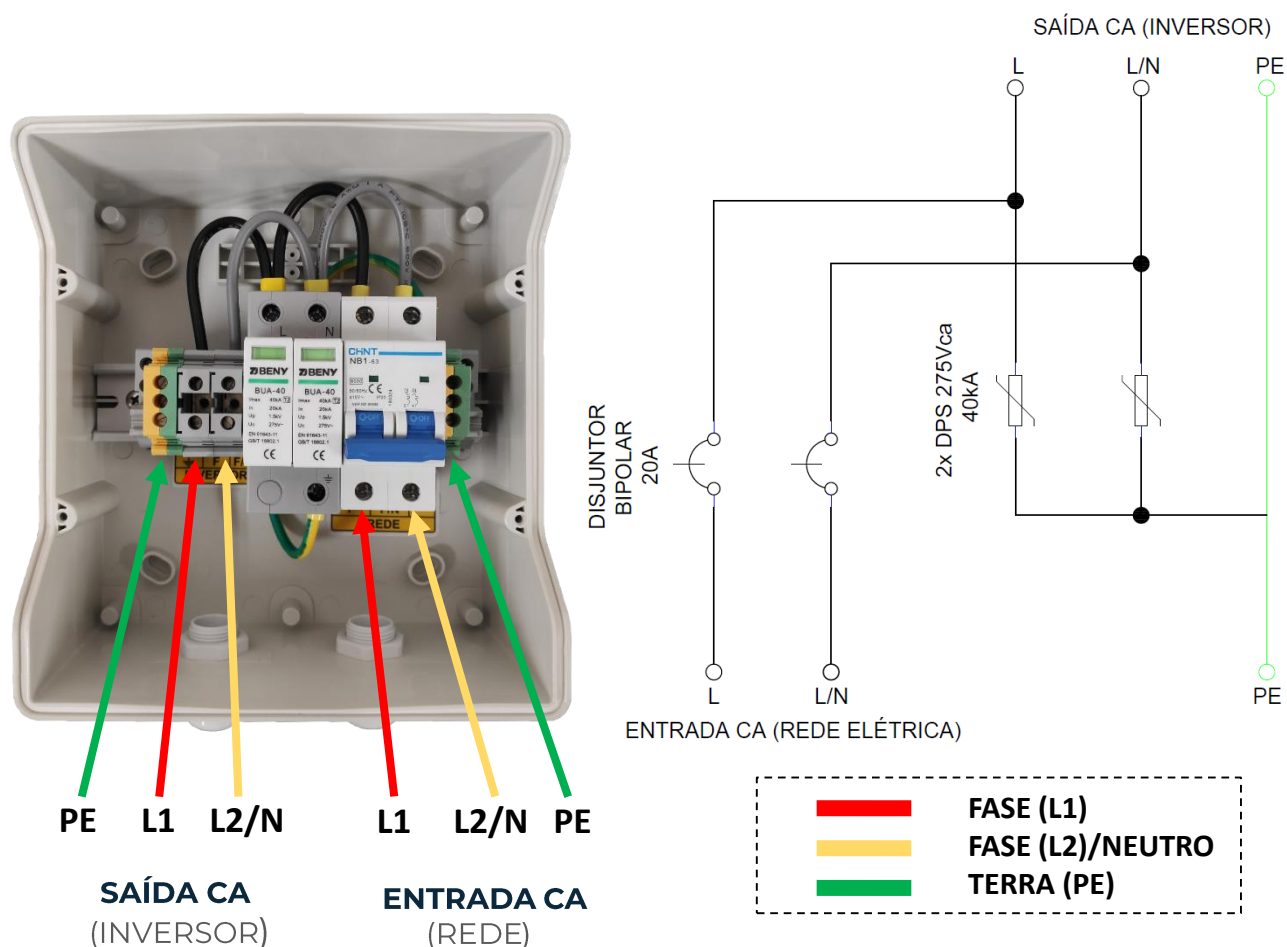

Rua São Bernardino nº 12  
Pq. Anhanguera - CEP: 05120-050  
São Paulo - SP



(11) 3648-7830  
contato@phb.com.br

